TS-63000

Temperature Sensor and Transducers

Product Bulletin

The TS-6300 series temperature sensors provide an active and passive signal that corresponds to the air or water temperature in heating, ventilating and air conditioning applications.

They provide either a 0...10 Vdc signal directly proportional to the sensed temperature, or a passive resistive signal NTC K2, NTC K10, Pt100, Pt1000.

The TS-6300 temperature sensor series has been designed to work with Metasys and System91 field controllers.



- **Wide range of mounting types and signal outputs**
Allows more flexibility in sensor selection.
- **Different length of tubes and wells for duct and immersion applications**
Senses the temperature at the desired location
- **Bayonet mounting system**
No screws required to close the cover. Easy installation and servicing
- **For immersion applications, well can be mounted before duct sensor is mounted**
Easy installation and servicing
- **IP54 Ingress Protection (except cable and remote sensor)**
Protection against condensation and water spray
- **IP67 Ingress Protection for cable and remote sensor**

Application

The TS-6300 are designed for measuring temperature in gaseous media of heating/cooling and air conditioning systems.

In combination with the thermo-well the sensor are suitable for measuring temperature in liquid fluids.

The TS-6300 series of temperature sensors provide, depending on the selected models:

- 0...10 Vdc voltage output
- NTC K2 resistance signal
- NTC K10 resistance signal
- Pt100 resistance signal (4 wires)
- Pt1000 resistance signal

The various TS-6300 output versions can be connected to the following Johnson Controls controllers:

- Metasys
- System 9100 series
- TC-8900 series
- TUC03 series

Ordering Codes

Item Code	Output	Mounting Type	Length	Temperature range
TS-6370D-A11	0...10VDC	Duct / Immersion	138 mm	-40...+50 °C
TS-6370D-B11			192 mm	
TS-6370D-C11			290 mm	
TS-6370D-D11			446 mm	
TS-6370D-A12			138 mm	-20...+40 °C
TS-6370D-B12			192 mm	
TS-6370D-C12			290 mm	
TS-6370D-D12			446 mm	
TS-6370D-A13			138 mm	0...+40 °C
TS-6370D-B13			192 mm	
TS-6370D-C13			290 mm	
TS-6370D-D13			446 mm	
TS-6370D-A14			138 mm	0...+100 °C
TS-6370D-B14			192 mm	
TS-6370D-C14			290 mm	
TS-6370D-D14			446 mm	
TS-6330D-A10	2K2 NTC	Duct / Immersion	138 mm	-40...+120 °C
TS-6330D-B10			192 mm	
TS-6330D-C10			290 mm	
TS-6330D-D10			446 mm	
TS-6340D-A10	10K NTC		138 mm	
TS-6340D-B10			192 mm	
TS-6340D-C10			290 mm	
TS-6340D-D10			446 mm	
TS-6350D-A10	Pt100		138 mm	
TS-6350D-B10			192 mm	
TS-6350D-C10			290 mm	
TS-6350D-D10			446 mm	
TS-6360D-A10	Pt1000		138 mm	
TS-6360D-B10			192 mm	
TS-6360D-C10			290 mm	
TS-6360D-D10			446 mm	
TS-6370R-F01	0...10VDC	Remote Sensor	2 m cable length	-40...+50 °C
TS-6370R-F03				0...+40 °C
TS-6370R-F04				0...+100 °C
TS-6330K-F00	2K2 NTC	Cable Sensor	2 m cable length	-20...+100 °C
TS-6340K-F00	10K NTC			
TS-6360K-F00	Pt1000			
TS-6370E-001	0...10VDC	Outdoor	---	-40...+50 °C
TS-6370E-002				-20...+40 °C
TS-6330E-000	2K2 NTC	Outdoor	---	-40...+50 °C
TS-6340E-000	10K NTC			
TS-6350E-000	Pt100			
TS-6360E-000	Pt1000			
TS-6370S-002	0...10VDC	Strap-on	---	-20...+40 °C
TS-6370S-004				0...+100 °C
TS-6330S-000	2K2 NTC	Strap-on	---	-20...+100 °C
TS-6340S-000	10K NTC			
TS-6350S-000	Pt100			
TS-6360S-000	Pt1000			
TS-6370C-E13	0...10VDC	Ceiling	36 mm	0...+40 °C
TS-6330C-E10	2K2 NTC	Ceiling	36 mm	0... +40 °C
TS-6340C-E10	10K NTC			
TS-6350C-E10	Pt100			
TS-6360C-E10	Pt1000			

Accessories

Item Code	Material	Mounting Thread	Lenght	Working Pressure
TS-6300W-E200	Brass/Copper	R 1/2"	50 mm	25 bar
TS-6300W-F200			120 mm	
TS-6300W-G200			150 mm	
TS-6300W-H200			200 mm	
TS-6300W-I200			260 mm	
TS-6300W-E300	Stainless Steel	R 1/2"	50 mm	40 bar
TS-6300W-F300			120 mm	
TS-6300W-G300			150 mm	
TS-6300W-H300			200 mm	
TS-6300W-I300			260 mm	
TS-6300W-E400		G 1/2"	50 mm	
TS-6300W-F400			120 mm	
TS-6300W-G400			150 mm	
TS-6300W-H400			200 mm	
TS-6300W-I400			260 mm	
TS-6300D-000	Duct Flange Kit			
TS-6300W-900	Retrofitting Thermowell Adapter Kit			

Mounting

The TS-63000 can be mounted in virtually any position.

For mounting follow the instructions below:

- Locate the sensors, where they will be exposed to representative conditions.
- Avoid non-representative air draughts, direct sunlight, etc.
- For strap-on models use a thermal conductive paste between well or pipe and sensor to improve reaction times.
- The sensor should not be exposed to direct radiation (lamps, radiators, etc.) or to the sun, since it would lead to incorrect measurement.

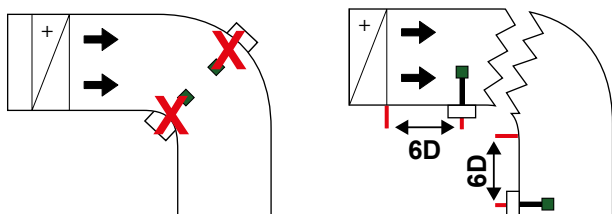

Place the sensor far enough away from bends, junctions or section changes in the duct to ensure an accurate reading.

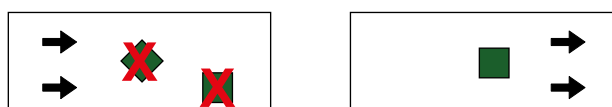

Install the sensor in the middle of the duct.

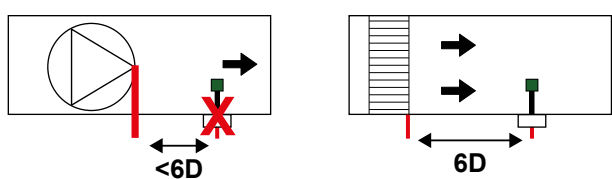

The preferred placement of the sensor is away from turbulent air caused by filters, rectifiers and coolers.

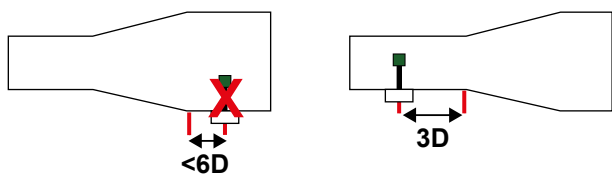

Place the sensor in front of diffusers or confusers.

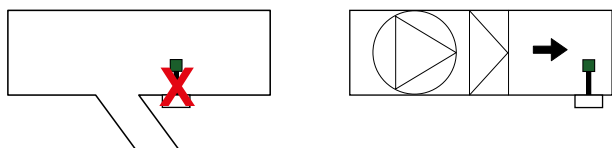

Filters and coolers calm the air flow.

Mounting Method

Ceiling Mount Model (TS-63x0C):

Two M4.5 or M4 (#10 or #8) screws, not included.
A seal ring is provided to seal around the probe between the enclosure and mounting surface.

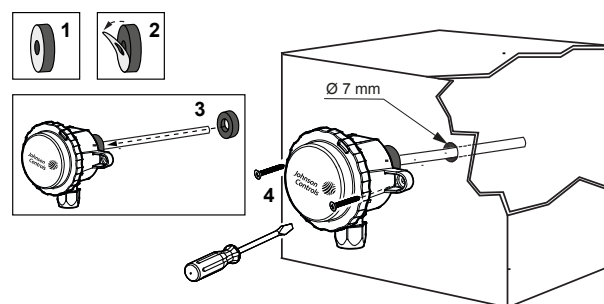

Duct/Immersion Model (TS-63x0D):

Two M4.5 or M4 (#10 or #8) screws, not included.
A seal ring is provided to seal around the probe between the enclosure and duct.
Duct Flange Kit is available as accessory for positioning TS-63000 inside the duct.

For immersion applications, direct mount to TS-6300W series thermowells.

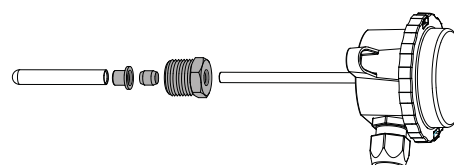
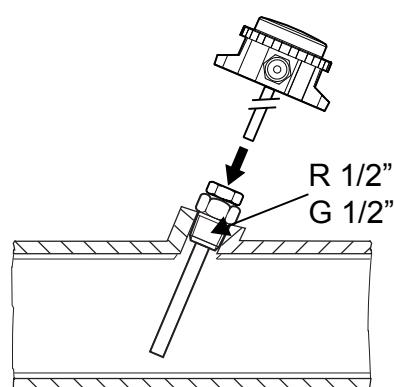

Duct/Immersion Model (TS-63x0D) with Retrofitting Kit (TS-6300W-900):

To mount new TS-63x0D on thermowell TS-9100 previously installed.

Note: Response time increases.

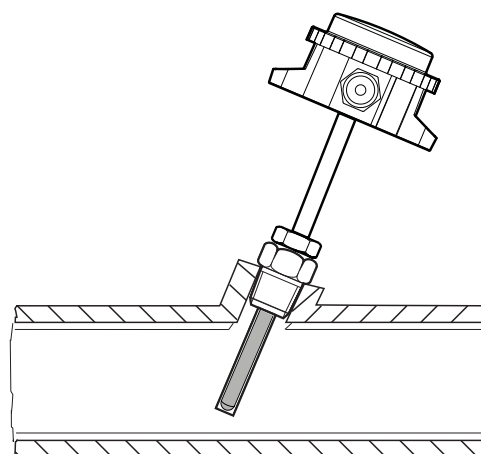

Mounting Method

Outdoor Model (TS-63x0E):

Two M4.5 or M4 (#10 or #8) screws, not included.

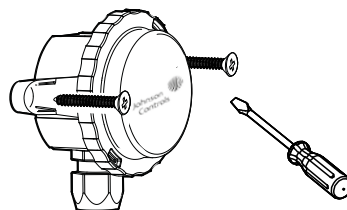

Strap Mount Model (TS-63x0S):

A Band clamp is included for 20 to 90 mm (0.78 to 3.54 inch) outside diameter pipe.

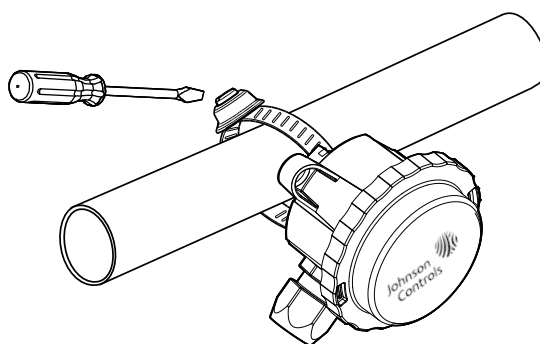

Remote Sensor Model (TS-6370R):

Two M4.5 or M4 (#10 or #8) screws, not included.
Use a clamp, cable-tie. For immersion applications use a TS-6300W-Ex00, 50 mm (2 inch) thermowell.

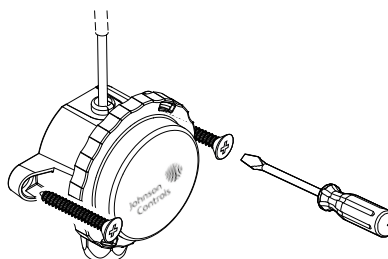

Cable Sensor Model (TS-63x0K):

No mounting hardware included.
Use a clamp, cable-tie, or hardware appropriate for the application. For immersion applications use a TS-6300W-Ex00, 50 mm (2 inch) thermowell.

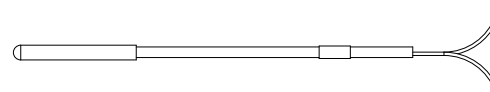

Wiring instructions

For wiring follow the instructions below:

- All wiring must be in accordance with local regulations and national rules.
- Do not attempt field repairs. If the transmitter is not operating properly, even though it is wired correctly, it should be replaced.

3 wires 0...10Vdc Output

The TS-6300 Active are 3 wires devices utilizing an RTD sensing element that goes through an amplifier circuit to provide a 0...10Vdc output proportional to the sensed temperature.

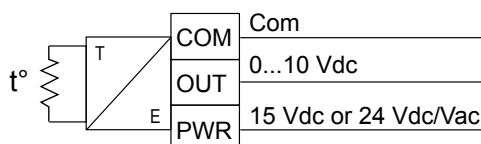

2 wires NTC K2 / NTC K10 / PT1000

The TS-6300 Series Sensors are two-wire devices utilizing an RTD or thermistor temperature sensing element. The sensing elements have a known response to temperature that provides a predictable and repeatable resistance/temperature (R/T) characteristic.

The RTD sensing elements are thin film platinum SMT chips. They have a positive temperature coefficient and are nearly linear over the operating temperature range.

The thermistor sensing elements are leaded, epoxy coated beads or chips. The thermistor sensing elements have a negative temperature coefficient (NTC) and are non-linear over the operating temperature range.

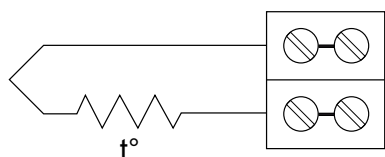

4 wires PT100

The 4-wire, 100 ohm, platinum RTD is used where improved measurement accuracy is desired.

The 4-wire design allows for a Kelvin-connection of the sensor to reduce the error caused by lead wire resistance and contact resistance (see Figure 6). A current source is input to terminals **I+** and **I-**, to provide a known current through the sensing element. The voltage drop across the sensing element is measured at **U+** and **U-**. The measured voltage is a function of the sensor resistance so that the measured temperature may be determined. The voltage measurement circuit should be high impedance to keep the current through **U+** and **U-** to a minimum so that the voltage drop across the measurement leads is insignificant.

The TS-6350x PT100 4-wire sensor models are not designed for use with Johnson Controls controllers or any specific third-party controller. Application of these products is at the customers discretion.

Note: The RTD sensor is not polarity sensitive. Terminal block labeling is for customer wiring convenience. Terminal markings plus (+) and minus (-) identify paired wires and the pairs are interchangeable. Terminals **U** and **I** are equivalent and are interchangeable.

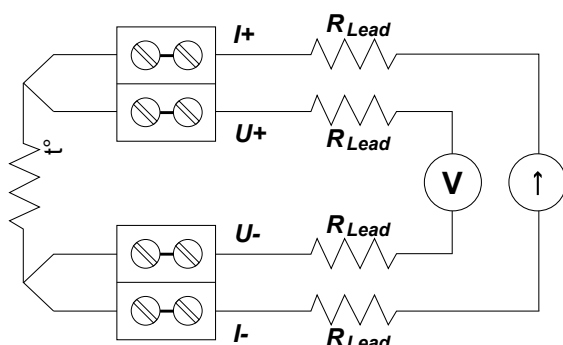

Resistance Tables

PT100 Sensor Resistance/Temperature Values

$R_0 = 100$		Resistance (ohms) at Temperature (°C)									
°C	0	-1	-2	-3	-4	-5	-6	-7	-8	-9	°C
-40	84.27	83.87	83.48	83.08	82.69	82.29	81.89	81.50	81.10	80.70	-40
-30	88.22	87.83	87.42	87.04	86.64	86.25	85.85	85.46	85.06	84.67	-30
-20	92.16	91.77	91.37	90.98	90.59	90.19	89.80	89.40	89.01	88.62	-20
-10	96.09	95.69	95.30	94.91	94.52	94.12	93.73	93.34	92.95	92.55	-10
0	100.00	99.61	99.22	98.83	98.44	98.04	97.65	97.26	96.87	96.48	0
°C	0	1	2	3	4	5	6	7	8	9	°C
0	100.00	100.39	100.78	101.17	101.56	101.95	102.34	102.73	103.12	103.51	0
10	103.90	104.29	104.68	105.07	105.46	105.85	106.24	106.63	107.02	107.40	10
20	107.79	108.18	108.57	108.96	109.35	109.73	110.12	110.51	110.90	111.29	20
30	111.67	112.06	112.45	112.83	113.22	113.61	114.00	114.38	114.77	115.15	30
40	115.54	115.93	116.31	116.70	117.08	117.47	117.86	118.24	118.63	119.01	40
50	119.40	119.78	120.17	120.55	120.94	121.32	121.71	122.09	122.47	122.86	50
60	123.24	123.63	124.01	124.39	124.78	125.16	125.54	125.93	126.31	126.69	60
70	127.08	127.46	127.84	128.22	128.61	128.99	129.37	129.75	130.13	130.52	70
80	130.90	131.28	131.66	132.04	132.42	132.80	133.18	133.57	133.95	134.33	80
90	134.71	135.09	135.47	135.85	136.23	136.61	136.99	137.37	137.75	138.13	90
100	138.51	138.88	139.26	139.64	140.02	140.40	140.78	141.16	141.54	141.91	100

PT1000 Sensor Resistance/Temperature Values

$R_0 = 1000$		Resistance (ohms) at Temperature (°C)									
°C	0	-1	-2	-3	-4	-5	-6	-7	-8	-9	°C
-40	842.71	838.75	834.75	830.79	826.87	822.90	818.94	814.97	811.00	807.03	-40
-30	882.22	878.27	874.32	870.38	866.43	862.48	858.53	854.57	850.62	846.66	-30
-20	921.60	917.67	913.73	909.80	905.86	901.92	897.98	894.04	890.10	886.16	-20
-10	960.86	956.94	953.02	949.09	945.17	941.24	937.32	933.39	929.46	925.53	-10
0	1000.00	996.09	992.18	988.27	984.36	980.44	976.53	972.61	968.70	964.78	0
°C	0	1	2	3	4	5	6	7	8	9	°C
0	1000.00	1003.91	1007.81	1011.72	1015.62	1019.53	1023.43	1027.33	1031.23	1035.13	0
10	1039.03	1042.92	1046.82	1050.72	1054.60	1058.49	1062.38	1066.27	1070.16	1074.05	10
20	1077.94	1081.82	1085.70	1089.59	1093.47	1097.35	1101.23	1105.10	1108.98	1112.86	20
30	1116.73	1120.60	1124.47	1128.35	1132.21	1136.08	1139.95	1143.82	1147.68	1151.55	30
40	1155.41	1159.27	1163.13	1166.99	1170.85	1174.70	1178.56	1182.41	1186.27	1190.12	40
50	1193.97	1197.82	1201.67	1205.52	1209.36	1213.21	1217.05	1220.90	1224.70	1228.58	50
60	1232.42	1236.26	1240.09	1243.93	1247.77	1251.60	1255.43	1259.26	1263.09	1266.92	60
70	1270.75	1274.58	1278.40	1282.23	1286.05	1289.87	1293.70	1297.52	1301.33	1305.15	70
80	1308.97	1312.78	1316.60	1320.41	1324.22	1328.03	1331.84	1335.65	1339.46	1343.26	80
90	1347.07	1350.87	1354.68	1358.48	1362.28	1366.08	1369.87	1373.67	1377.47	1381.26	90
100	1385.06	1388.85	1392.64	1396.43	1400.22	1404.00	1407.79	1411.58	1415.36	1419.14	100

2K2 NTC Thermistor Sensor Resistance/Temperature Values

<i>Resistance (ohms) at Temperature (°C)</i>											
°C	0	-1	-2	-3	-4	-5	-6	-7	-8	-9	°C
-40	75487.3	80682.2	86274.5	92297.4	98787.1	105783	113329	121472	130264	139761	-40
-30	39759.4	42309.9	45042.9	47972.7	51115.1	54486.7	58106.1	61993.1	66169.6	70659.0	-30
-20	21831.5	23139.4	24535.0	26024.9	27616.0	29316.0	31132.9	33075.8	35154.0	37378.1	-20
-10	12451.6	13149.5	13891.4	14680.4	15519.6	16412.8	17363.7	18376.4	19455.3	20605.3	-10
0	7352.80	7739.06	8148.22	8581.79	9041.38	9528.72	10045.7	10594.2	11176.5	11794.8	0
°C	0	1	2	3	4	5	6	7	8	9	°C
0	7352.80	6988.04	6643.48	6317.88	6010.10	5717.07	5443.79	5183.33	4936.81	4703.41	0
10	4482.37	4272.96	4074.51	3886.40	3708.03	3538.84	3378.32	3225.98	3081.35	2944.01	10
20	2813.56	2689.61	2571.80	2459.81	2353.31	2252.00	2155.61	2063.88	1976.55	1893.39	20
30	1814.18	1738.72	1666.80	1598.25	1532.89	1470.55	1411.09	1354.35	1300.19	1248.49	30
40	1199.12	1151.97	1106.92	1063.87	1022.73	983.39	945.78	909.80	875.38	842.44	40
50	810.91	780.73	751.83	724.15	697.63	672.23	647.87	624.53	602.15	580.68	50
60	560.10	540.34	521.39	503.19	485.73	468.96	452.85	437.38	422.51	408.23	60
70	394.50	381.30	368.61	356.41	344.67	333.37	322.50	312.05	301.98	292.28	70
80	282.95	273.96	265.30	256.96	248.92	241.17	233.70	226.49	219.55	212.85	80
90	206.39	200.15	194.14	188.33	182.73	177.32	172.09	167.05	162.18	157.47	90
100	152.92	148.52	144.27	140.17	136.20	132.36	128.65	125.05	121.58	118.22	100

10K NTC Thermistor Sensor Resistance/Temperature Values

<i>Resistance (ohms) at Temperature (°C)</i>											
°C	0	-1	-2	-3	-4	-5	-6	-7	-8	-9	°C
-40	336185	359383	384362	411271	440275	471552	505296	541722	581063	623574	-40
-30	176827	188191	200370	212430	229439	242473	258616	275957	294593	314630	-30
-20	97011.1	102830	109040	115670	122751	130318	138407	147057	145313	166219	-20
-10	55303.6	58405.5	61703.1	65210.1	68941.2	72912.3	77140.2	81642.5	86441.9	91556.8	-10
0	32650.0	34365.6	36183.1	38109.1	40150.8	42315.9	44612.6	47049.9	49637.2	52384.8	0
°C	0	1	2	3	4	5	6	7	8	9	°C
0	32650.0	31029.9	29499.6	28053.5	26686.7	25394.2	24171.8	23015.2	21920.5	20884.1	0
10	19902.6	18972.8	18091.7	17256.4	16464.5	15713.3	15000.6	14324.2	13682.1	13072.4	10
20	12493.2	11942.9	11419.8	10922.6	10449.8	10000.00	9572.06	9964.78	8777.06	8407.85	20
30	8056.19	7721.14	7401.85	7097.49	6807.29	6530.52	6266.49	6014.55	5774.09	5544.53	30
40	5325.32	5115.95	4915.92	4724.77	4542.07	4367.40	4200.36	4040.59	3887.74	3741.47	40
50	3601.47	3467.44	3339.09	3216.17	3098.40	2985.56	2877.41	2773.73	2674.33	2579.00	50
60	2487.55	2399.81	2315.62	2234.81	2157.23	2082.74	2011.19	1942.47	1876.44	1812.99	60
70	1752.00	1693.37	1636.99	1582.78	1530.63	1480.45	1432.17	1385.71	1340.98	1297.92	70
80	1256.45	1216.51	1178.03	1140.96	1105.24	1070.81	1037.62	1005.62	974.77	945.01	80
90	916.30	888.60	861.87	836.08	811.18	787.14	763.93	741.51	719.86	698.94	90
100	678.73	659.20	640.32	622.07	604.43	587.37	570.88	554.92	539.49	524.55	100

Dimensions (mm)

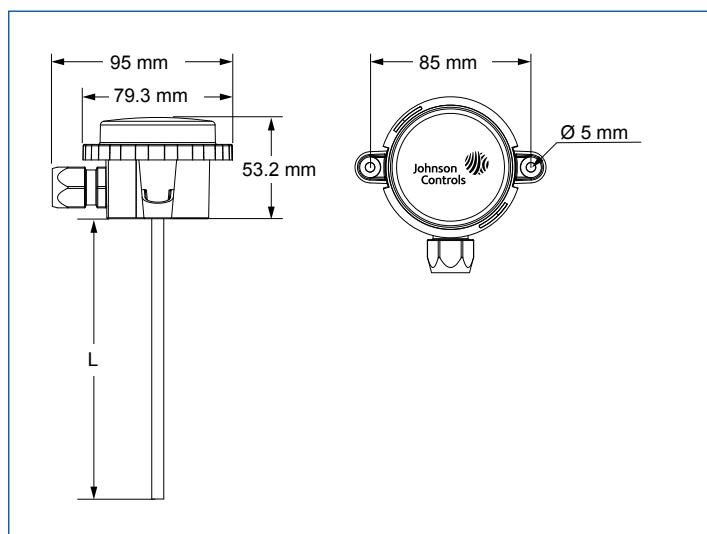

Duct and Ceiling

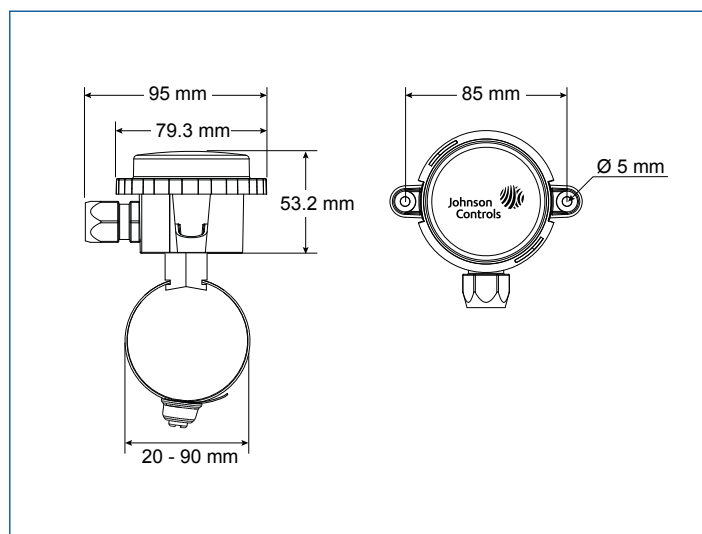

Strap-on

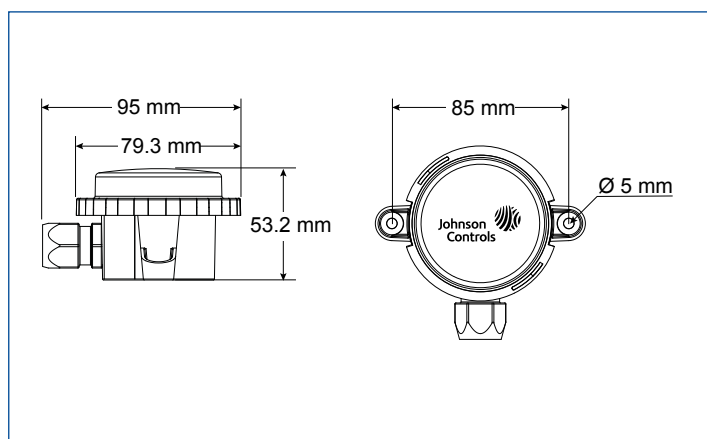

Outdoor

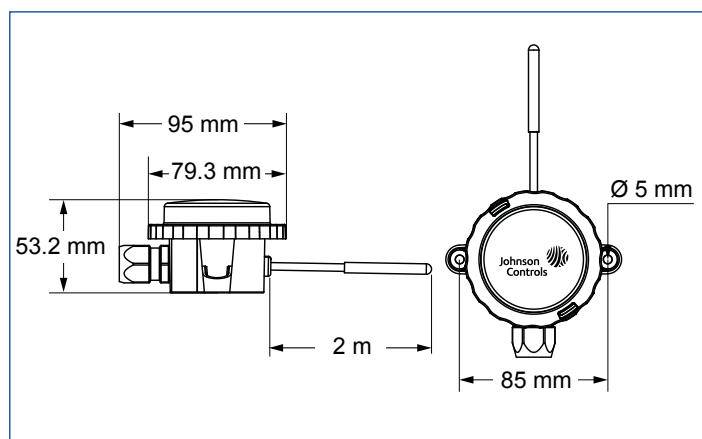

Remote

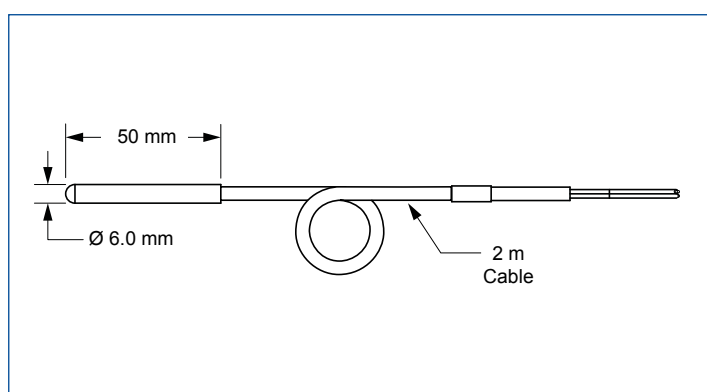

Cable

Accessories - Dimensions (mm)

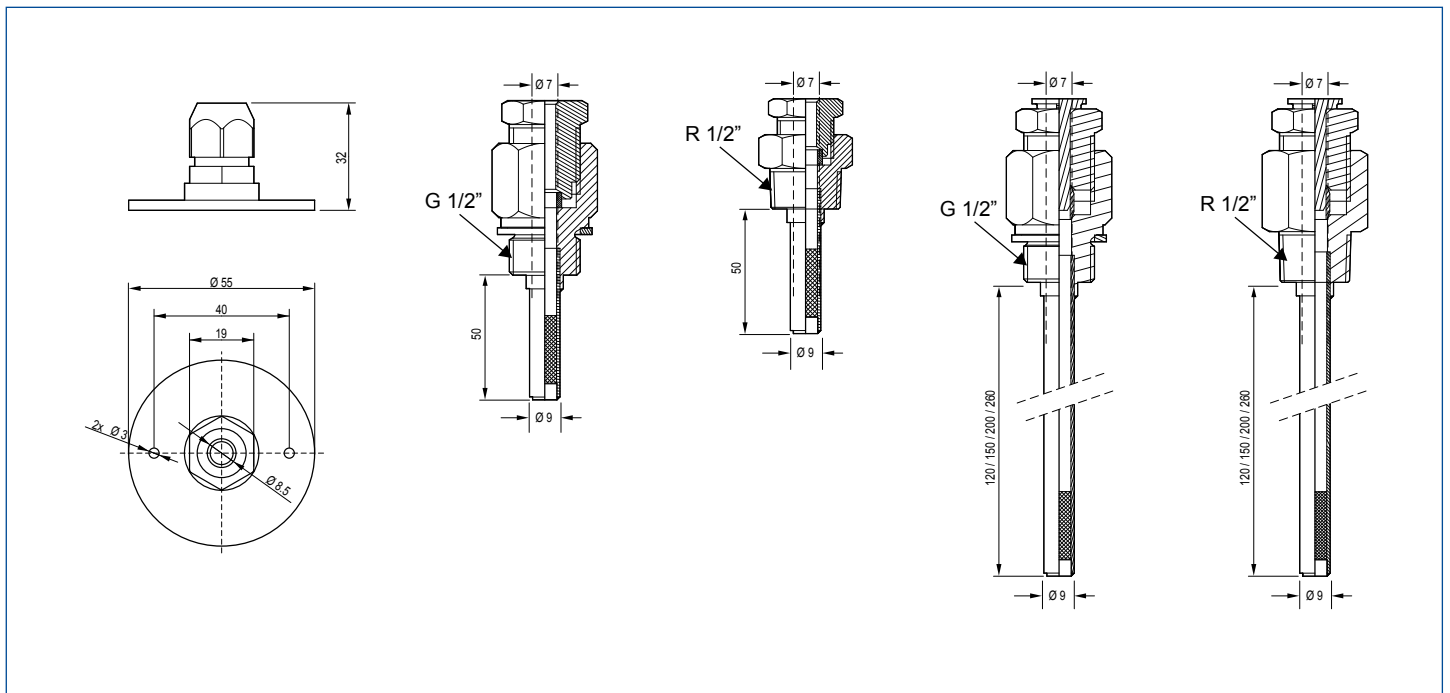

Technical Specifications

	0...10Vdc	K2 NTC Thermistor	K10NTC Thermistor	PT100 RTD	PT1000 RTD
Power Supply	15 Vdc ± 10% 24 Vac ±20% 24 Vdc ±15%	---	---	---	---
Output Signal	0...10 Vdc	2252 ohm @ 25 °C	10 kohm @ 25 °C, Johnson Controls Type II	100 ohm @ 0 °C, per EN 60751	1000 ohm @ 0 °C, per EN 60751
Output Accuracy	± 1% FS or 0.5 °C	± 0.2 C° (± 0.36 F°), from 0 to 70 °C	± 0.5 C° (± 0.9 F°), from 0 to 70 °C	EN 60751, Class A, ± (0.15 + 0.002 * T °C)	EN 60751, Class A, ± (0.15 + 0.002 * T °C)
- Measurement Current*	5 mA Maximum	0.1 mA Recommended 1 mA Maximum	0.1 mA Recommended 2 mA Maximum	1 mA Recommended 5 mA Maximum	0.3 mA Recommended 2 mA Maximum
Max Operating Temperature for Enclosure w/PWA					
- Operating Temperature	-40 to 70 °C (-40 to 158 °F)				
- Storage Temperature	-40 to 70 °C (-40 to 158 °F)				
- Transit Temperature	-40 to 70 °C (-40 to 158 °F)				
Humidity					
- Operating Humidity	5 % to 95 %RH, non-condensing, 30 °C (86 °F) Max Dew Point				
Storage Conditions					
- Storage Humidity	5 % to 95 %RH, non-condensing, 30 °C (86 °F) Max Dew Point				
- Transit	5 % to 95 %RH, non-condensing, 30 °C (86 °F) Max Dew Point				
Protection**					
- Protection Class	IP54 according to IEC 60529				
	Exceptions: TS-63x0K Cable or Remote Sensor (without enclosure), probe: IP67				
Material					
- Housing	Polycarbonate, Lexan EXL9330				
- Probe	Stainless Steel 304				
- Cable sensor probe	Stainless Steel 304 or 316				
Color					
- Housing	Blue, PMS 300				
Terminations					
- Terminal Type	Screw-clamp type terminal block				
- Max Wire Size	1 x 1.5 mm ² (16 AWG)				
CE Compliance	Johnson Controls, Inc., declares that this product is in compliance with the essential requirements and other relevant provisions of the EMC Directive 2004/108/EC.				

* Measurement error at Maximum current may excessive from self heating.

The performance specifications are nominal and conform to acceptable industry standards. For application at conditions beyond these specifications, consult the local Johnson Controls office. Johnson Controls, Inc. shall not be liable for damages resulting from misapplication or misuse of its products.